

# Wheel Stud Service Kit

10611

**TIGER  
TOOL**

Have What It Takes

## Safety Warning

**Read all instructions and safety warnings prior to operation. Failure to do so could result in equipment damage, personal injury or even death.**

- **Stay Alert!** Watch what you are doing and use common sense when operating this tool.
- Inspect product for damage prior to using; do not use if product is in unsafe condition.
- Do not operate tool while under the influence of drugs, alcohol or medication.
- Always use safety equipment to prevent injuries. Approved face and eye protection must always be worn by the operator, as well as others in the work area.
- Do not overreach. Keep proper footing and balance at all times.
- Dress properly. Do not wear loose clothing or jewelry. Keep your hair, clothing and gloves away from moving parts.
- Keep your work area clean and well lit.



View demonstration videos and a complete product list at [tigertool.com](http://tigertool.com)

Technical Support  
1.800.661.4661

# Wheel Stud Service Kit

10611

**TIGER  
TOOL**

Have What It Takes

## Operating Instructions

### Wheel Stud Removal

- 1 Install the appropriate stud removal adaptor into the opposing end of the C-frame. **Figure A**
- 2 Position the 10611 over the wheel stud and apply pneumatic pressure until the wheel stud is released from the hub flange. **Figure B**

### Wheel Stud Installation

- 1 Insert the installation adaptor into the opposing C-frame. **Figure C**
- 2 For installation of  $\frac{3}{4}$ " or 22 mm studs you must select the appropriate aluminum sleeve and place it over the protruding threaded area of the stud. **Figure D**

Place the installation tube housing over the aluminum installation sleeve. The aluminum sleeve is not required on  $1\frac{1}{8}$ " studs.

- 3 Position the tool over the wheel stud installation tube and continue to apply pneumatic pressure until the stud is securely seated into the hub flange.

Here at Tiger Tool, your satisfaction is our number one priority. Should you have any questions about this or any of our products, please call us at 1.800.661.4661.



Figure A



Figure B



Figure C



Figure D



View demonstration videos and a complete product list at [tigertool.com](http://tigertool.com)

Technical Support  
1.800.661.4661

# Wheel Stud Service Kit

10611

**TIGER  
TOOL**

Have What It Takes

## Parts Breakdown

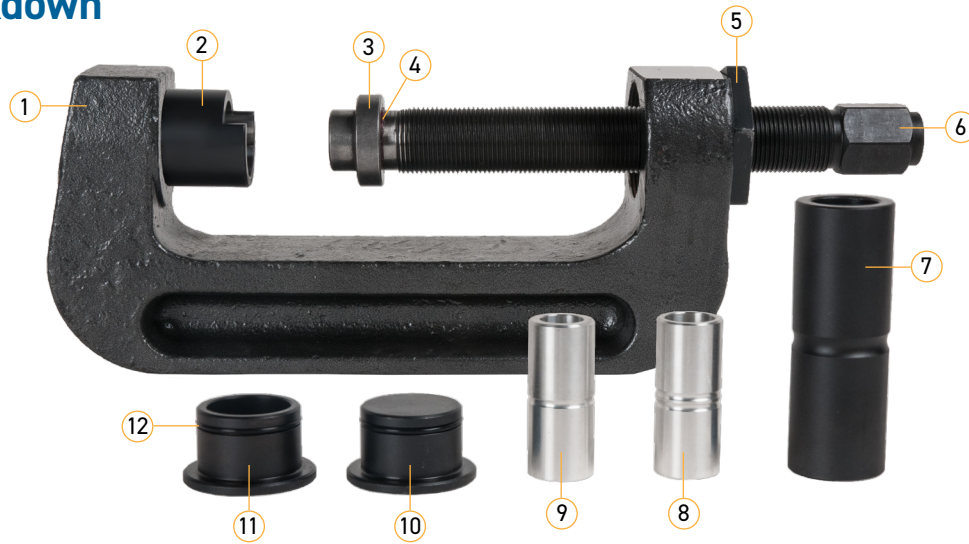

Item No.	Part Number	Description	Qty.
1	10608-1	Frame	1
2	10608-5	Stud Installer – Long (Blind Notched Removal Adaptor)	1
3	10611-1	Manual Wheel Stud Anvil	1
4	90150-14	O-Ring	1
5	10608-13	Threaded Adapter	1
6	90150-4	1 3/4" Forcing Screw	1
7	10608-18	22mm Installation Tube	1
8	10608-22	22mm Aluminum Sleeve	1
9	10608-21	3/4" Aluminum Sleeve	1
10	10608-4	Stud Installation Anvil	1
11	10608-7	Stud Removal Sleeve Thru Hole	1
12	10608-12	O-Ring	3



View demonstration videos and a complete product list at [tigertool.com](http://tigertool.com)

Technical Support  
1.800.661.4661