

10730 to 15000 Pin & Bushing Upgrade Kit

10731

**TIGER
TOOL**

Have What It Takes

Safety Warning

Read all instructions and safety warnings prior to operation. Failure to do so could result in equipment damage, personal injury, or even death.

CAUTION: USE REPLACEMENT PARTS AND ACCESSORIES PROVIDED BY TIGER TOOL ONLY. ALL REPLACEMENT PARTS AND ACCESSORIES ARE AVAILABLE. KEEP HYDRAULIC COUPLER PROTECTED WHEN NOT IN USE. DUST CAPS SHOULD BE USED ON COUPLERS WHEN NOT IN USE TO AVOID CONTAMINANTS FROM ENTERING THE HYDRAULIC CYLINDER AND POWER SOURCE. THIS PRACTICE WILL HELP TO EXTEND THE LIFE OF THIS PRODUCT AND ENSURE CONTINUED CONSISTENT OPERATION.

- **Stay Alert!** Watch what you are doing and use common sense when operating this tool.
- Inspect product for damage prior to using; do not use if product is in unsafe condition.
- Do not operate tool while under the influence of drugs, alcohol, or medication.
- Always use safety equipment to prevent injuries. Approved face and eye protection must always be worn by the operator, as well as others in the work area.
- Do not overreach. Keep proper footing and balance at all times.
- Dress properly. Do not wear loose clothing or jewelry. Keep your hair, clothing and gloves away from moving parts.
- Keep hands clear of all pressurized hydraulic components.
- Always ensure hoses are free from sharp bends and kinks.
- Keep your work area clean and well lit.
- Cylinders are designed for 10,000 psi (700 bar) maximum working pressure. Do not connect to a pump with a higher rated pressure. Use a pressure gauge in the system at all times. Ensure all components in the system are rated for 10,000 psi (700 bar).



View demonstration videos and a complete product list at tigertool.com

Technical Support
1.800.661.4661

10730 to 15000 Pin & Bushing Upgrade Kit 10731

**TIGER
TOOL**

Have What It Takes

Operating Instructions using 10730 & 10731

View the 15000 (Pin & Bushing Service Kit) demonstration video online at tigertool.com

Note: When using the 10731 in conjunction with your existing 10730, it's important to note that figure A list parts from the 10730 in which you can omit when utilizing your 10730 to 15000 Leaf Spring & Bushing Upgrade Kit.

Removing Spring Eye Pin and Bushing

- 1 Support the truck by the chassis in an approved method so that the front suspension is unloaded.
- 2 Support the front axle assembly so that the shackles (side bars) can be removed from the trailing end of the spring eye and chassis bushings.
- 3 Remove the shackles from the trailing end of the front leaf springs on both sides of the vehicle. The vehicle can now be raised or the axle lowered to provide easy access to the spring eye pin and bushing.

Be aware of all other vehicle components that might be affected by this procedure such as brake lines and wiring. Ensure no damage is caused.

- 4 Place the removal split adapters over the inboard end of the pin bushing assembly - large end of the split adapter against the spring bushing. Then slide the supplied o-ring into the groove to hold them in place. The removal split adapters have an outside diameter slightly smaller than the bushing OD. The installation split adapters have an OD larger than the bushing OD. Ensure you have the smaller removal split adapters.

- 5 Slide the retainer sleeve over the split adapters. **(Figures 2)**

Note: Optional split adapters used for demonstration purposes.

A

- | | |
|-------------------------|-----------------------------|
| 1 15001-58 Pull Adapter | 5 15001-55 Cylinder Adapter |
| 2 15001-60 Adapter Pin | 6 15001-61 2.625" Tube Cap |
| 3 15001-59 Push Adapter | 7 15001-56 3 1/4" Tube Cap |
| 4 15001-57 Spacer Tube | |

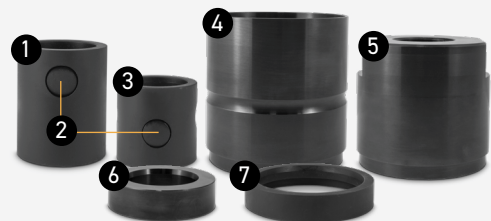

1

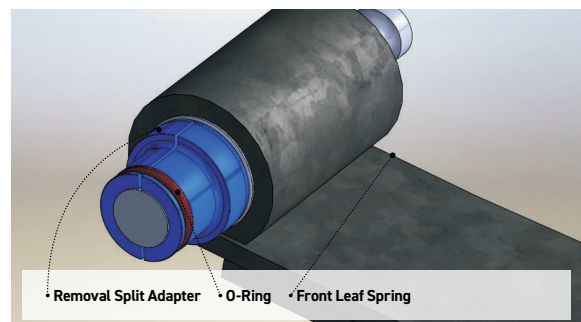

2



View demonstration videos and a complete product list at tigertool.com

Technical Support
1.800.661.4661

10730 to 15000 Pin & Bushing Upgrade Kit

10731

**TIGER
TOOL**

Have What It Takes

Removing Spring Eye Pin and Bushing Cont.

- 6 Attach the pullbar to the outboard end of the spring bushing. This is done with the pullbar split adapters and pullbar retainer sleeve.

The pullbar split adapter, pullbar, and bushing pin connect together. **(Diagram 3)**

Place both halves of the pullbar split adapter over the bushing pin and the head of the pullbar. Now slide the pullbar retaining sleeve down the pullbar and over the split adapters.

Diagram 4 shows the pullbar retaining sleeve being installed. Be sure the pullbar retaining sleeve fully covers the pullbar split adapters.

- 7 Connect the face adapter and extension tube together and slide them over the pullbar retaining sleeve. **(Figures 5 and 6)**

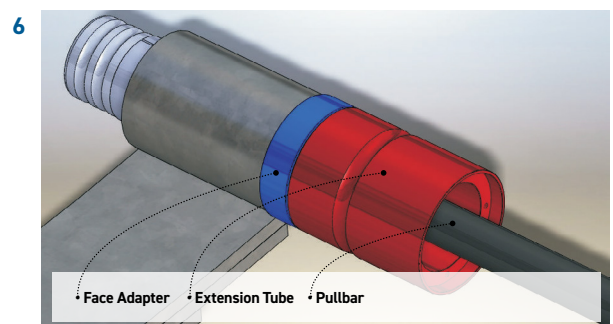
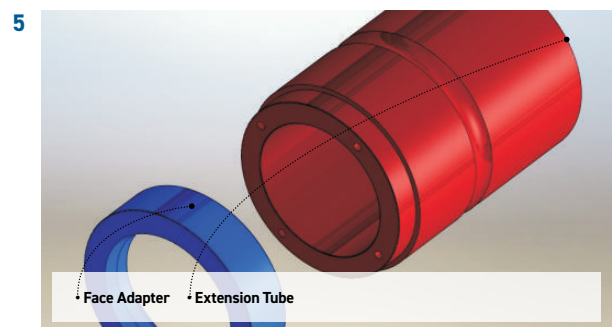
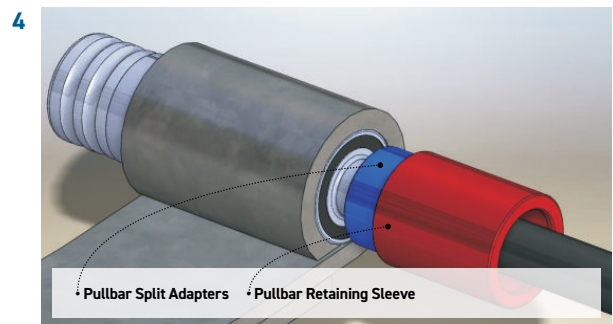
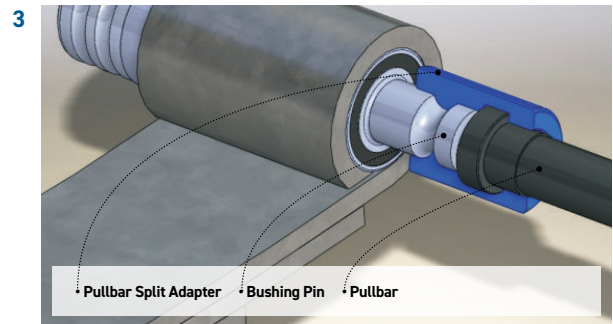

View demonstration videos and a complete product list at tigertool.com

Technical Support
1.800.661.4661

10730 to 15000 Pin & Bushing Upgrade Kit

10731

**TIGER
TOOL**

Have What It Takes

Removing Spring Eye Pin and Bushing Cont.

- 8 Thread the cylinder tube onto the hydraulic cylinder. Slide the hydraulic cylinder/cylinder tube assembly over the pullbar, cylinder tube first. **(Figures 7 & 8)**
- 9 Thread on the retaining nut and tighten by hand until tight. This will hold everything in place. The 20 ton hydraulic cylinder will provide the power required to remove the pin bushing. Do final check to ensure all the parts are still in place—the face adapter should be flush against the spring face or the bushing housing. **(Figure 9)**
- 10 Apply hydraulic pressure—the bushing is pulled partially from the spring eye or bushing housing. **(Figure 10)**

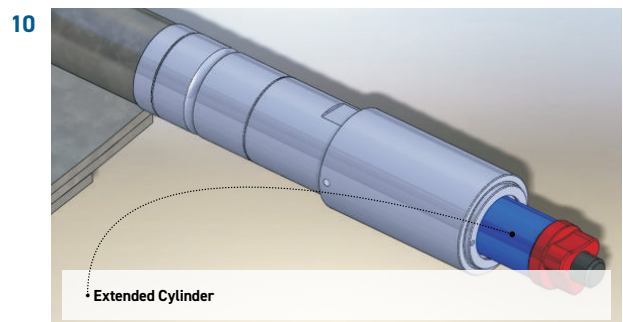
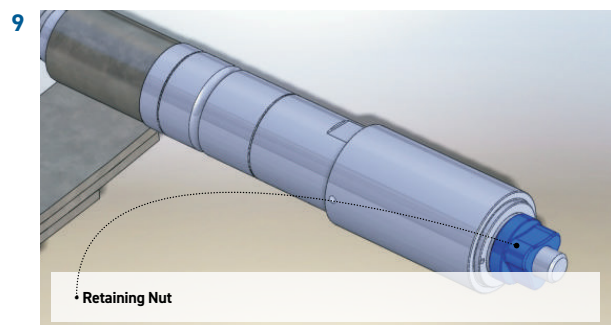
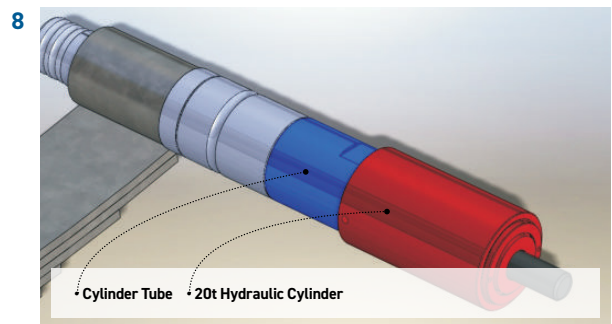
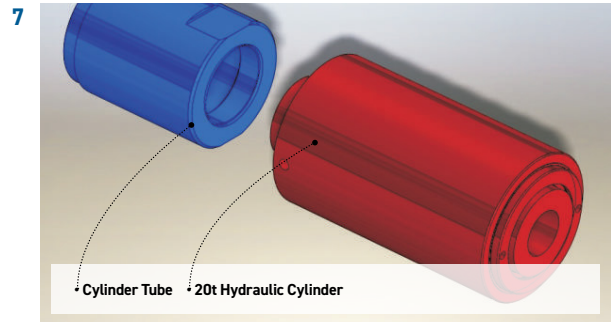

View demonstration videos and a complete product list at tigertool.com

Technical Support
1.800.661.4661

10730 to 15000 Pin & Bushing Upgrade Kit

10731

**TIGER
TOOL**

Have What It Takes

Removing Spring Eye Pin and Bushing Cont.

- 11 Remove hydraulic pressure allowing the hydraulic cylinder to retract.
- 12 Tighten the retaining nut by hand until tight to take up the slack. Check to ensure all parts are still in place. **(Figure 11)**
- 13 Apply hydraulic pressure, the hydraulic cylinder extends and the bushing is pulled fully from the spring eye or bushing housing. If the bushing is not fully removed from the spring eye or housing, repeat steps 11 through 13.

See cross section of the bushing fully removed from the spring eye. **(Figure 12)**

11

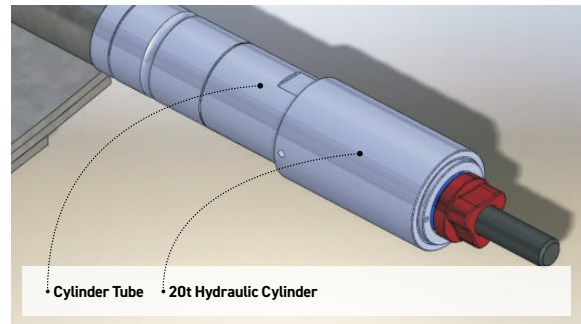

12

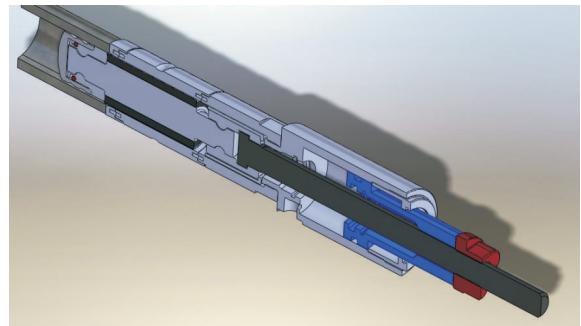

View demonstration videos and a complete product list at tigertool.com

Technical Support
1.800.661.4661

10730 to 15000 Pin & Bushing Upgrade Kit

10731

**TIGER
TOOL**

Have What It Takes

Operating Instructions using 10730 & 10731

Installing Spring Eye Pin and Bushing

NOTE: Optional split adapters were used for this demonstration.

It is recommended that after removing a bushing/pin assembly, you immediately install the new bushing/pin assembly. The instructions given here follow that methodology. Note this tool pulls the bushing/pin assembly into the spring eye from the inboard side of the spring.

- 1 Disassemble the previous puller assembly leaving the cylinder tube attached to the hydraulic cylinder.
- 2 On the bench, attach the install split adapters, o-ring, and retaining sleeve to one end of the bushing/pin assembly in the same method as step 5 and 6 removal. **(Figure 13)**
- 3 Slide the pullbar through the spring eye from the outboard side of the spring. Attach the new bushing/pin assembly with the pullbar split adapters and the pullbar retaining sleeve in the same method as removal step 7. **(Figure 14)**

13

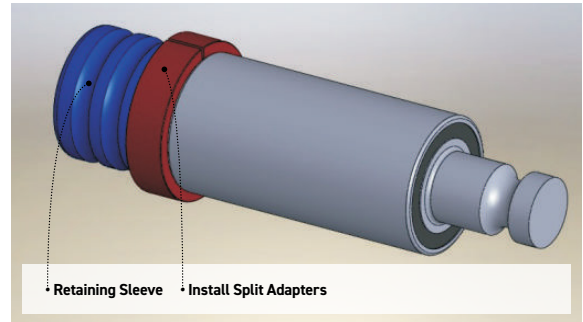

14

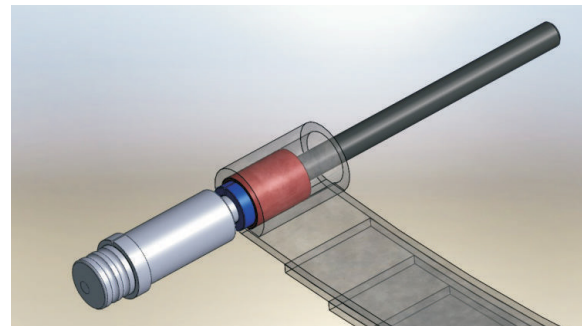

View demonstration videos and a complete product list at tigertool.com

Technical Support
1.800.661.4661

10730 to 15000 Pin & Bushing Upgrade Kit

10731

**TIGER
TOOL**

Have What It Takes

Installing Spring Eye Pin and Bushing Cont.

- 4 Slide the face adapter over the cylinder tube end and slide the cylinder, cylinder tube, and face adapter over the pullbar.
- 5 Spin on the retaining nut and tighten by hand to take up the slack (**figure 15**). Double check that the bushing/pin assembly is in alignment with the bore of the spring eye.
- 6 Apply hydraulic pressure to the cylinder and the bushing/pin assembly is pulled partially into the spring eye. Release pressure allowing the cylinder to retract. Tighten the retaining nut and apply hydraulic pressure once again to pull the bushing/pin assembly farther into the spring eye. The install split adapters are larger than the OD of the bushing and will stop the bushing/pin assembly at the correct installation distance.
- 7 Disassemble the tool from the bushing/pin assembly.
- 8 Replace remaining bushing/pin assemblies as required.

15

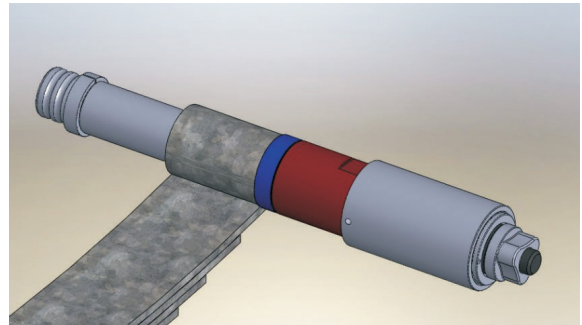

View demonstration videos and a complete product list at tigertool.com

Technical Support
1.800.661.4661

10730 to 15000 Pin & Bushing Upgrade Kit

10731

**TIGER
TOOL**

Have What It Takes

Parts Breakdown



Item No.	Part Number	Description	Qty.
1	15001-77	Large Face Adapter	1
2	15031-1	Retaining Ring	2
3	15001-75	Cylinder Adaptor	1
4	15001-76	Extension Tube	1
5	15001-23	Cylinder Tube Cap	1
6	15001-10	Large O-Ring	2
7	15001-10A	Small O-Ring	2



View demonstration videos and a complete product list at tigertool.com

Technical Support
1.800.661.4661

10730 to 15000 Pin & Bushing Upgrade Kit

10731

**TIGER
TOOL**

Have What It Takes

Parts Breakdown



Item No.	Part Number	Description	Qty.
8	15001-17	1 3/4" Pull Adapter	2
9	15001-4	2 1/6" Pull Adapter	2
10	15001-2	Large Retaining Cap	1
11	15001-16	Small Retaining Cap	1
12	15001-5	Pullbar Retaining Sleeve	1
13	15001-18	Small Pullbar Retaining Sleeve	1



View demonstration videos and a complete product list at tigertool.com

Technical Support
1.800.661.4661