

Hydraulic Bearing Race Starter Kit w/o Cylinder

10910

**TIGER
TOOL**[®]

Have What It Takes

Safety Warning

Read all instructions and safety warnings prior to operation. Failure to do so could result in equipment damage, personal injury or even death.

CAUTION: USE REPLACEMENT PARTS AND ACCESSORIES PROVIDED BY TIGER TOOL ONLY. ALL REPLACEMENT PARTS AND ACCESSORIES ARE AVAILABLE. KEEP HYDRAULIC COUPLER PROTECTED WHEN NOT IN USE. DUST CAPS SHOULD BE USED ON COUPLERS WHEN NOT IN USE TO AVOID CONTAMINANTS FROM ENTERING THE HYDRAULIC CYLINDER AND POWER SOURCE. THIS PRACTICE WILL HELP TO EXTEND THE LIFE OF THIS PRODUCT AND ENSURE CONTINUED CONSISTENT OPERATION.

- **Stay Alert!** Watch what you are doing and use common sense when operating this tool.
- Inspect product for damage prior to using; do not use if product is in unsafe condition.
- Do not operate tool while under the influence of drugs, alcohol or medication.
- Always use safety equipment to prevent injuries. Approved face and eye protection must always be worn by the operator, as well as others in the work area.
- Do not overreach. Keep proper footing and balance at all times.
- Dress properly. Do not wear loose clothing or jewelry. Keep your hair, clothing and gloves away from moving parts.
- Keep hands clear of all pressurized hydraulic components.
- Always ensure hoses are free from sharp bends and kinks.
- Keep your work area clean and well lit.
- Cylinders are designed for 10,000 psi (700 bar) maximum working pressure. Do not connect to a pump with a higher rated pressure. Use a pressure gauge in the system at all times. Ensure all components in the system are rated for 10,000 psi (700 bar).



View demonstration videos and a complete product list at tigertool.com

Technical Support
1.800.661.4661

Hydraulic Bearing Race Starter Kit w/o Cylinder

10910

**TIGER
TOOL**[®]

Have What It Takes

Operating Instructions

The 10910 Hydraulic Bearing Race Starter Kit combines with your previously purchased 17202 Hydraulic Cylinder.

Race Removal

CAUTION: Always follow Manufacturers recommendations when servicing bearing races.

- 1 Choose the corresponding adapter kit required for the bearing set/race number.
(Figure D)
- 2 Place the spit ring over the tapered disk wedge (tapered faces together).
(Figure A)
- 3 Place the clamp plate on top of the split ring and disk wedge assembly and finger-tighten the supplied hex flange screws.
- 4 Insert the clamp assembly into the hub with the heads of the flanged hex screws facing the direction the race is to be pulled.
(Figure B)
- 5 Align the groove in the split ring with the minor diameter of the race.
(Figure C)
- 6 Using a helper if required and the handle on the back-end for support, apply torque to the two hex flanged screws – alternating the applied force between the screws until the clamp plate and disk wedge have come into contact.
(Figure C)



View demonstration videos and a complete product list at tigertool.com

Technical Support
1.800.661.4661

Hydraulic Bearing Race Starter Kit w/o Cylinder

10910

**TIGER
TOOL**[®]

Have What It Takes

Operating Instructions

Race Removal Continued

CAUTION: Always follow Manufacturers recommendations when servicing bearing races.

- 7 Insert the long length of threaded rod into the clamp disk assembly and thread into place until the rod bottoms-out on the aluminum handle in the back of the disk assembly.
(Figure E)
- 8 Thread the hat supplied onto the 20T hydraulic cylinder.
(Figure F)
- 9 Slide the hydraulic cylinder and hat assembly onto the threaded rod being careful to align the cut outs on the hat with the axle studs on the hub.
(Figure G)
- 10 Install the supplied washer and nut on the end of the hydraulic cylinder assembly – thread the nut all the way such that the washer is tightly sandwiched between the nut and the piston on the cylinder.
- 11 Using a 10,000psi hydraulic pump, actuate the cylinder until the bearing race is free from the hub.
- 12 Pull the whole assembly out of the hub and disassemble the components.
(Figure H)

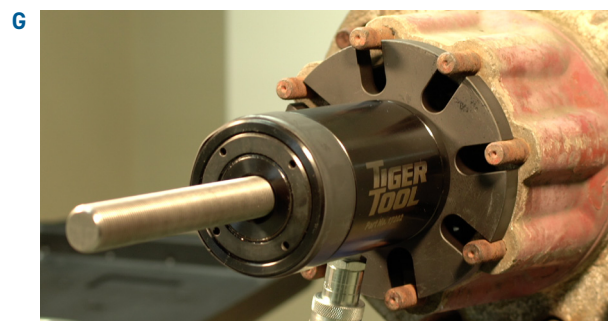
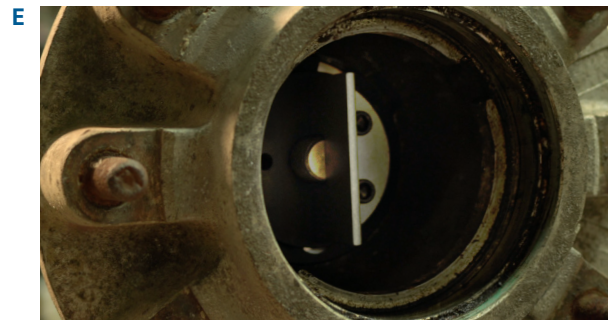

View demonstration videos and a complete product list at tigertool.com

Technical Support
1.800.661.4661

Hydraulic Bearing Race Starter Kit w/o Cylinder

10910

**TIGER
TOOL**[®]

Have What It Takes

Operating Instructions

Race Installation

CAUTION: Always follow Manufacturers recommendations when servicing bearing races.

- 1 Thoroughly clean the hub and remove any burrs from the race seat.
- 2 Lay the wheel/tire assembly on its side and position the new race in the hub with the corresponding install adapter on to the race.
(Figure A)
- 3 Using a hammer tap the install plate evenly around the outer perimeter to get the race started parallel to the seat.
- 4 Remove the install plate and lift the wheel/tire assembly upright.
- 5 Insert the threaded rod into the install adapter with a supplied washer and nut against the flat side of the install plate.
- 6 Insert the rod and install adapter through the hub with the tapered side of the adapter to the tapered side of the race.
(Figure B)
- 7 Place the hydraulic cylinder and hat over the threaded rod and install supplied washer and nut hand tight.



View demonstration videos and a complete product list at tigertool.com

Technical Support
1.800.661.4661

Hydraulic Bearing Race Starter Kit w/o Cylinder

10910

**TIGER
TOOL**[®]

Have What It Takes

Operating Instructions

Race Installation Continued

CAUTION: Always follow Manufacturers recommendations when servicing bearing races.

- 8 Make sure the assembly is centered on the hub.
(Figure C)
- 9 Using a 10,000psi hydraulic pump, apply force until the race is seated (approximately 4,000 -5,000 psi).
9A Make sure the race is being pulled parallel to the race seat, minor adjustments may be required with a hammer while installing).
(Figure D)
- 10 Release the hydraulic pressure and disassemble the tool.
- 11 Take care of oil all parts and return to the tool box supplied. Proper maintenance of parts ensures a long lifetime.

Here at Tiger Tool, your satisfaction is our number one priority. Should you have any questions about this or any of our products, please call us at 1.800.661.4661.



View demonstration videos and a complete product list at tigertool.com

Technical Support
1.800.661.4661

Hydraulic Bearing Race Starter Kit w/o Cylinder

10910

**TIGER
TOOL**[®]

Have What It Takes

Parts Breakdown

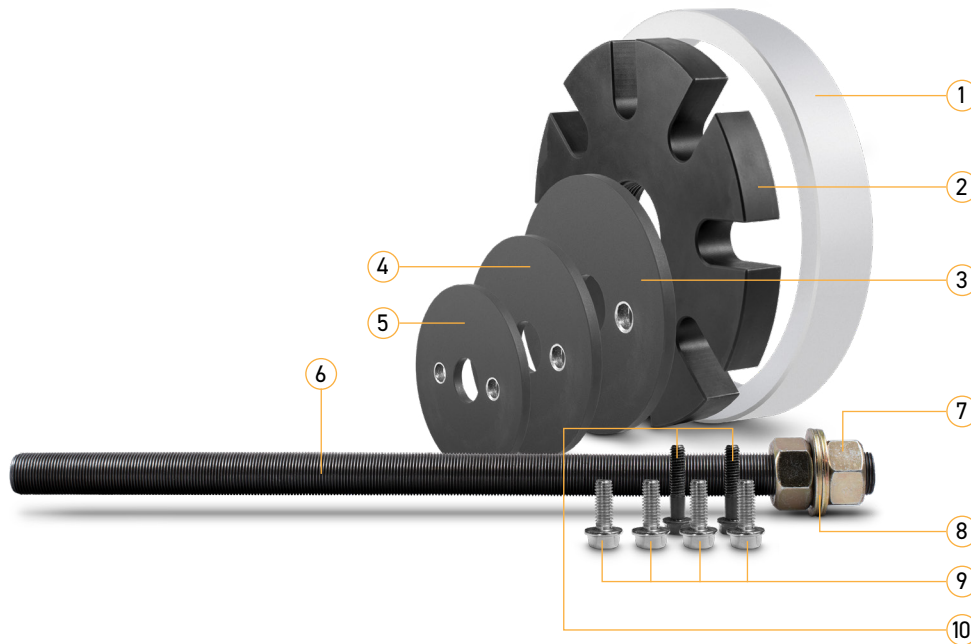

Item No.	Part Number	Description	Qty.
1	10908-7	Spacer Ring	1
2	10909-7	Hat	1
3	10908-2	Clamp B Plate	1
4	10908-4	Clamp A Plate	1
5	10908-6	Clamp C Plate	1
6	15001-40B	Threaded Rod	1
7	15001-41	Hex Nut	2
8	15001-42	Washer	2
9	10908-9	3/8" - 16 Hex Flange Screw	4
10	10908-10	5/16" - 18 Hex Flange Screw	2



View demonstration videos and a complete product list at tigertool.com

Technical Support
1.800.661.4661

Hydraulic Bearing Race Starter Kit w/o Cylinder

10910

**TIGER
TOOL**

Have What It Takes

Parts Breakdown

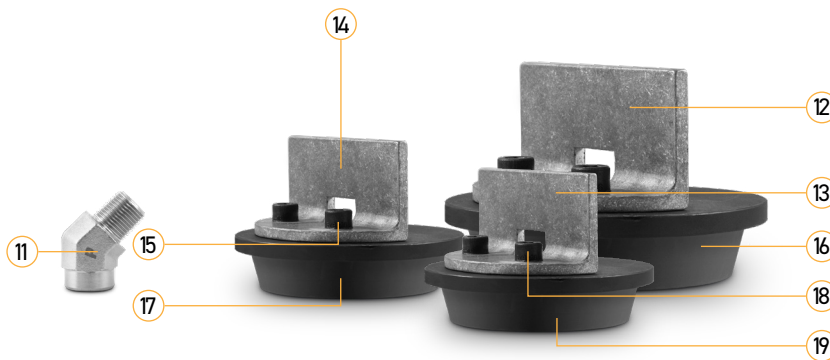

Item No.	Part Number	Description	Qty.
11	10909-9	45° Elbow	1
12	10909-6	4" Handle	1
13	10909-4	2 ¾" Handle	1
14	10909-5	3.625" Handle	1
15	17202-13	3/8-16 x ½" SHCS	4
16	10909-3	4.813" Disk Wedge	1
17	10909-2	3.938" Disk Wedge	1
18	10909-8	¼-20 X ½" SHCS	2
19	10909-1	2.9375" Disk Wedge	1



View demonstration videos and a complete product list at tigertool.com

Technical Support
1.800.661.4661