

# U-Joint Service Kit

20102

**TIGER  
TOOL**

Have What It Takes

## Safety Warning

**Read all instructions and safety warnings prior to operation. Failure to do so could result in equipment damage, personal injury or even death.**

**CAUTION:** FAILURE TO CHECK THE SPHERICAL THRUST WASHER AND REPLACE AS NECESSARY MAY RESULT IN UNREPAIRABLE DAMAGE TO YOUR U-JOINT PULLER GLOVE CASTING. PREVENTATIVE MAINTENANCE AS OUTLINED ON NEXT PAGE WILL ENSURE MANY YEARS OF USE FROM YOUR TIGER TOOL PULLER. FAILURE TO PERFORM PREVENTATIVE MAINTENANCE WILL VOID YOUR WARRANTY. FOR 10104 & 10105, DO NOT USE OVER ½" IMPACT WRENCH. DOING SO WILL VOID WARRANTY.

- **Stay Alert!** Watch what you are doing and use common sense when operating this tool.
- Inspect product for damage prior to using; do not use if product is in unsafe condition.
- Do not operate tool while under the influence of drugs, alcohol or medication.
- Always use safety equipment to prevent injuries. Approved face and eye protection must always be worn by the operator, as well as others in the work area.
- Do not overreach. Keep proper footing and balance at all times.
- Dress properly. Do not wear loose clothing or jewelry. Keep your hair, clothing and gloves away from moving parts.
- Keep your work area clean and well lit.

**NOTE:** HAMMERING THIS TOOL WILL VOID YOUR WARRANTY.



View demonstration videos and a complete product list at [tigertool.com](http://tigertool.com)

Technical Support  
1.800.661.4661

# U-Joint Service Kit

20102

**TIGER  
TOOL**

Have What It Takes

## Operating Instructions

### U-Joint Puller: 10102 & 10104

- 1 Remove all fasteners from bearing cups.
- 2 Slip the U-Joint Puller over the yoke of the driveline.
- 3 Turn the tool's forcing screw clockwise with either an air or hand wrench. (Note: reverse thread)
- 4 Once the bearing cup has been removed, repeat the process on the remaining bearing cups.

The 10102 U-Joint Puller may be used with up to a 1" impact wrench without voiding warranty. 10104 and 10105 can use ½" impact.

### Preventative Maintenance

Keep forcing screw clean and lubricated at all times. Failure to maintain the spherical thrust washer located inside the glove will result in excessive wear to the part. Check and lubricate this part (lubricate load bearing surface in glove, under cap, on both sides of spherical washer) periodically and replace as necessary. Contact your Dealer or Tiger Tool for replacement washers. (We recommend SAE 30 lube for the threads and EP with 'molly grease').

### Bolt-Retained Bearing Cup Installer MK4: 10201

- 1 Ensure all parts to be assembled are clean and/or greased where applicable.
- 2 Double check all needle bearings are present and placed correctly.
- 3 Start pressing bearing cup into yoke by hand, making sure the u-joint cross and bearing cup bolt holes line up.
- 4 Place installer onto bearing cup, threading the bolts into yoke.
- 5 Using an impact or hand wrench, turn forcing screw until cup is flush to the yoke.
- 6 Remove tool, and install bearing cup bolts.

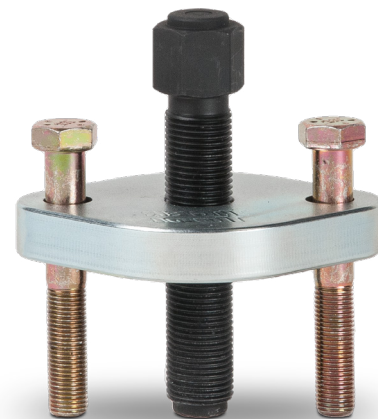
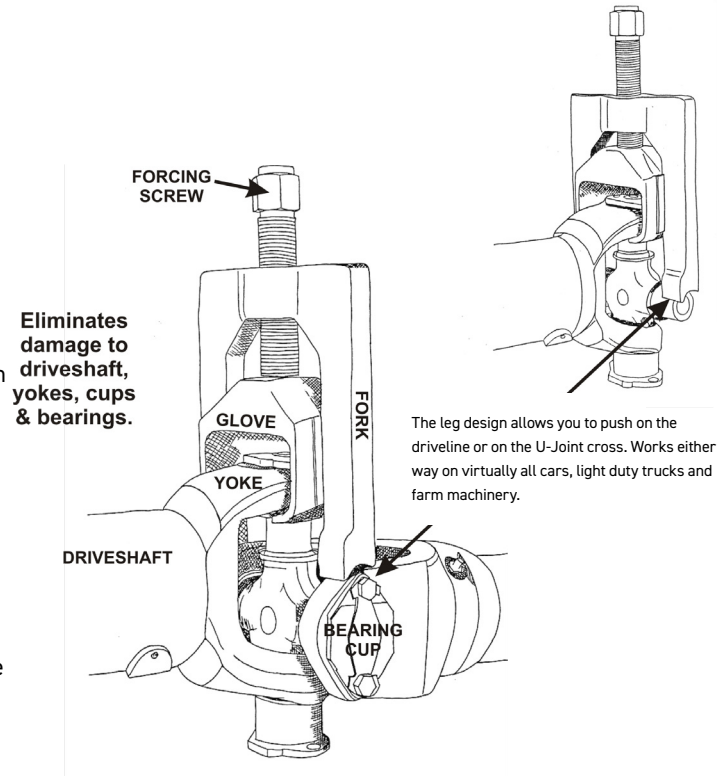

View demonstration videos and a complete product list at [tigertool.com](http://tigertool.com)

Technical Support  
1.800.661.4661

# U-Joint Service Kit

20102

**TIGER  
TOOL**

Have What It Takes

## Bearing Cup Installer: 10217

- 1 If necessary, select the SPL 170 or SPL 140 reducer for your application and insert into bottom of the SPL 250 Adapter.
- 2 Position u-joint cross and bearing cup onto the yoke. Ensure grease fitting is in the correct position.
- 3 Reverse the Forcing Screw so the tool can be positioned over the yoke/bearing cup.
- 4 By hand, tighten the Forcing Screw until the bottom of the frame of the tool is contacting the yoke making sure the adapter is centered over the bearing cup.
- 5 By ratchet or impact wrench, apply force to the forcing screw to press the bearing cup into the yoke. Make sure the u-joint cross keeps the needle bearings of the bearing cup in place.
- 6 Once the adapter/reducer is pressed flush against the yoke, reverse the forcing screw to remove the tool.
- 7 Rotate driveline 180 degrees.
- 8 By hand, insert the opposing bearing cup into the yoke.
- 9 Repeat steps 3 to 6 on remaining bearing cups.



Here at Tiger Tool, your satisfaction is our number one priority. Should you have any questions about this or any of our products, please call us at 1.800.661.4661.



View demonstration videos and a complete product list at [tigertool.com](https://www.tigertool.com)

Technical Support  
1.800.661.4661

# Heavy Duty U-Joint Puller

10102

**TIGER  
TOOL**

Have What It Takes

## Parts Breakdown

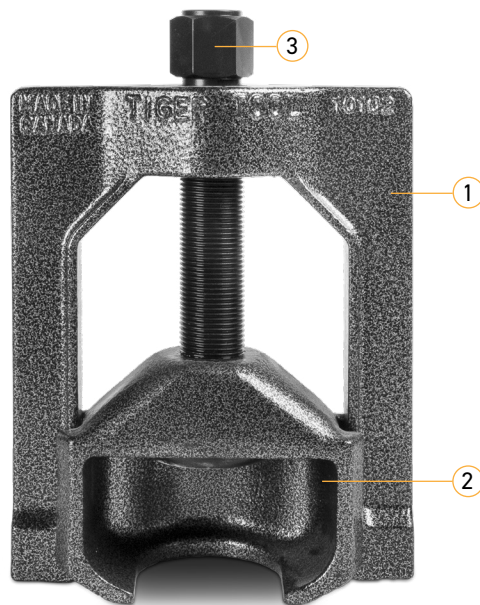

### Maintenance Pack for 10102

10101

Contains each of the following items:

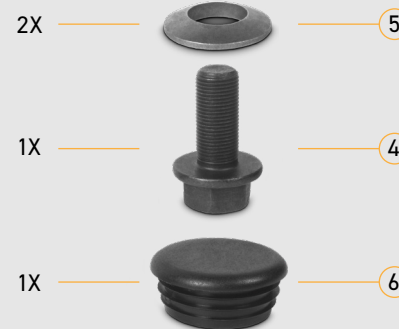

Also available separately.

Item No.	Part Number	Description	Qty.
1	10102-1	Fork	1
2	10102-2	Glove	1
3	10102-3	Forcing Screw	1
4	10102-4	Retaining Bolt	1
5	10102-5	Washer	1
6	10102-6	Dome Plug	1



View demonstration videos and a complete product list at [tigertool.com](http://tigertool.com)

Technical Support  
1.800.661.4661

# U-Joint Puller

10104

**TIGER  
TOOL**

Have What It Takes

## Parts Breakdown

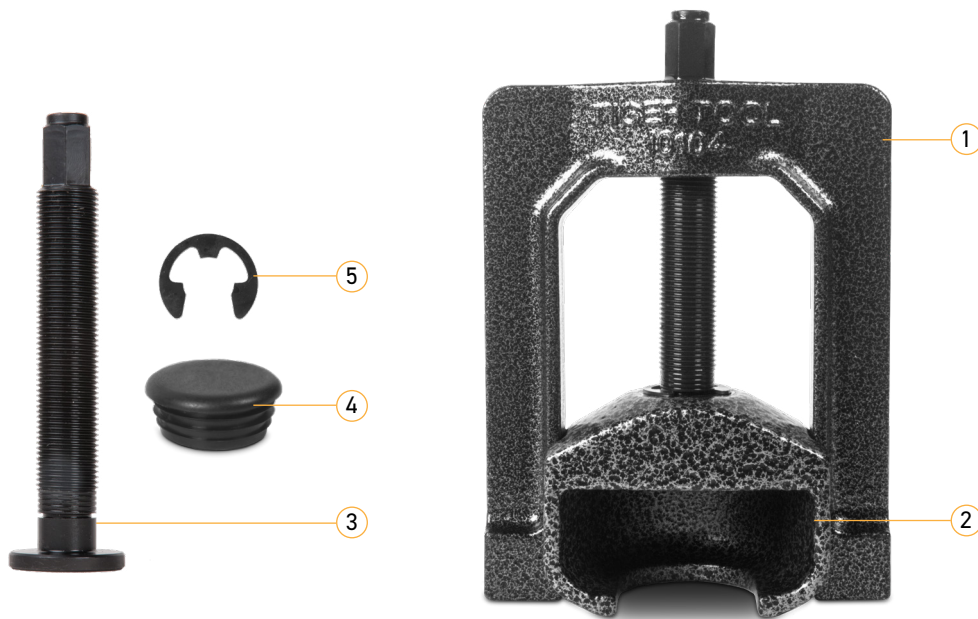

Item No.	Part Number	Description	Qty.
1	10104-1	Fork	1
2	10104-2	Glove	1
3	10104-4	Forcing Screw	1
4	10104-5	Dome Plug	1
5	10104-6	External Snap Ring	1



View demonstration videos and a complete product list at [tigertool.com](http://tigertool.com)

Technical Support  
1.800.661.4661

# Bolt-Retained Bearing Cup Installer

10201



Have What It Takes

## Parts Breakdown

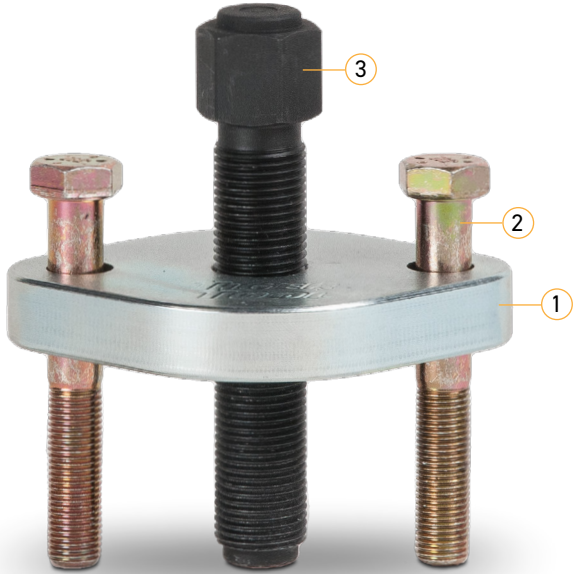

Item No.	Part Number	Description	Qty.
1	10201-1	Plate	1
2	10201-2	Bolt	2
3	10201-3	Forcing Screw	1



View demonstration videos and a complete product list at [tigertool.com](http://tigertool.com)

Technical Support  
1.800.661.4661

# Bearing Cup Installer

10217

**TIGER  
TOOL**

Have What It Takes

## Parts Breakdown

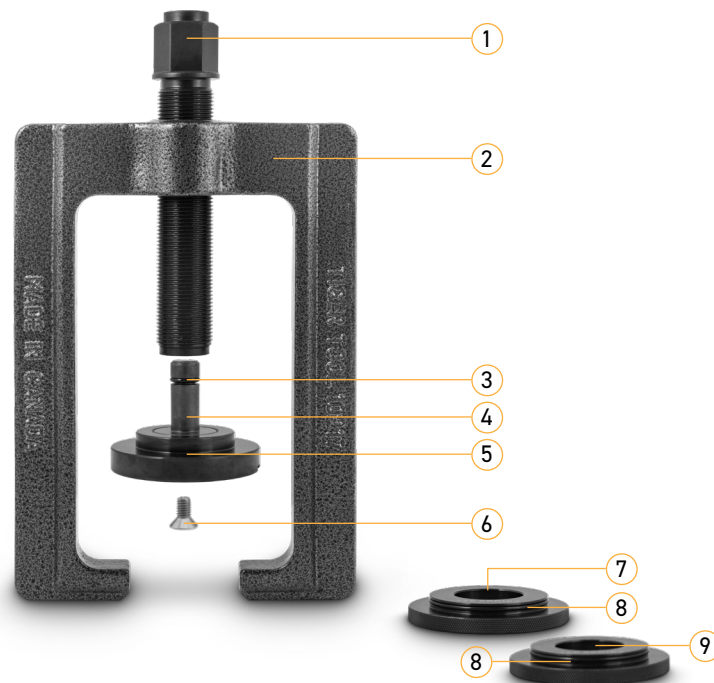

Item No.	Part Number	Description	Qty.
1	10217-9	Forcing Screw	1
2	10217-1	Fork	1
3	90150-14	O-Ring	1
4	10218-3	Installer Anvil	1
5	10218-13	SPL 250 Adpater	1
6	10100-5	FHMS 3/8" - 16 x 3/4"	1
7	10217-2	170 Series Reducer	1
8	10218-12	O-Ring	2
9	10217-7	140 Series Reducer	1



View demonstration videos and a complete product list at [tigertool.com](http://tigertool.com)

Technical Support  
1.800.661.4661